

Please check the examination details below before entering your candidate information

Candidate surname

Other names

**Pearson Edexcel
Level 3 GCE**

Centre Number

--	--	--	--	--

Candidate Number

--	--	--	--	--

Monday 3 June 2019

Morning (Time: 1 hour 30 minutes)

Paper Reference **9FM0/01**

Further Mathematics

Advanced

Paper 1: Core Pure Mathematics 1

You must have:

Mathematical Formulae and Statistical Tables (Green), calculator

Total Marks

Candidates may use any calculator permitted by Pearson regulations. Calculators must not have the facility for algebraic manipulation, differentiation and integration, or have retrievable mathematical formulae stored in them.

Instructions

- Use **black** ink or ball-point pen.
- If pencil is used for diagrams/sketches/graphs it must be dark (HB or B).
- **Fill in the boxes** at the top of this page with your name, centre number and candidate number.
- Answer **all** questions and ensure that your answers to parts of questions are clearly labelled.
- Answer the questions in the spaces provided
– *there may be more space than you need.*
- You should show sufficient working to make your methods clear.
Answers without working may not gain full credit.
- Answers should be given to three significant figures unless otherwise stated.

Information

- A booklet 'Mathematical Formulae and Statistical Tables' is provided.
- There are 8 questions in this question paper. The total mark for this paper is 75.
- The marks for **each** question are shown in brackets
– *use this as a guide as to how much time to spend on each question.*

Advice

- Read each question carefully before you start to answer it.
- Try to answer every question.
- Check your answers if you have time at the end.

Turn over ►

P61177A

©2019 Pearson Education Ltd.

1/1/1/1/1/1/1/



Pearson

3.

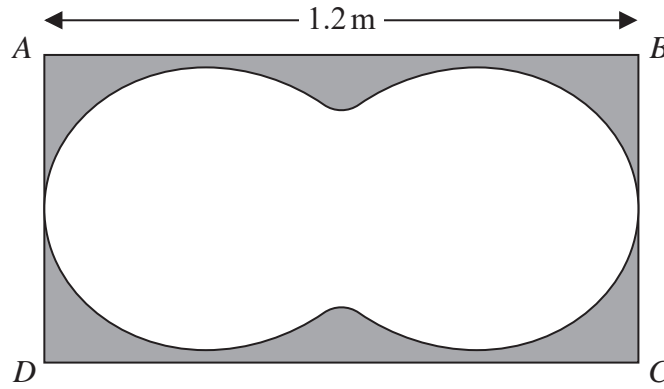

Diagram not to scale

Figure 1

Figure 1 shows the design for a table top in the shape of a rectangle $ABCD$. The length of the table, AB , is 1.2 m. The area inside the closed curve is made of glass and the surrounding area, shown shaded in Figure 1, is made of wood.

The perimeter of the glass is modelled by the curve with polar equation

$$r = 0.4 + a \cos 2\theta \quad 0 \leq \theta < 2\pi$$

where a is a constant.

(a) Show that $a = 0.2$

(2)

Hence, given that $AD = 60$ cm,

(b) find the area of the wooden part of the table top, giving your answer in m^2 to 3 significant figures.

(8)

DO NOT WRITE IN THIS AREA



4. Prove that, for $n \in \mathbb{Z}, n \geq 0$

$$\sum_{r=0}^n \frac{1}{(r+1)(r+2)(r+3)} = \frac{(n+a)(n+b)}{c(n+2)(n+3)}$$

where a, b and c are integers to be found.

(5)

DO NOT WRITE IN THIS AREA

DO NOT WRITE IN THIS AREA

DO NOT WRITE IN THIS AREA



Question 4 continued

DO NOT WRITE IN THIS AREA

DO NOT WRITE IN THIS AREA

DO NOT WRITE IN THIS AREA



P 6 1 1 7 7 A 0 1 5 3 2

Question 5 continued

DO NOT WRITE IN THIS AREA

DO NOT WRITE IN THIS AREA

DO NOT WRITE IN THIS AREA

(Total for Question 5 is 13 marks)



7. The line l_1 has equation

$$\frac{x-1}{2} = \frac{y+1}{-1} = \frac{z-4}{3}$$

The line l_2 has equation

$$\mathbf{r} = \mathbf{i} + 3\mathbf{k} + t(\mathbf{i} - \mathbf{j} + 2\mathbf{k})$$

where t is a scalar parameter.

- (a) Show that l_1 and l_2 lie in the same plane. (3)
- (b) Write down a vector equation for the plane containing l_1 and l_2 . (1)
- (c) Find, to the nearest degree, the acute angle between l_1 and l_2 . (3)



8. A scientist is studying the effect of introducing a population of white-clawed crayfish into a population of signal crayfish.

At time t years, the number of white-clawed crayfish, w , and the number of signal crayfish, s , are modelled by the differential equations

$$\frac{dw}{dt} = \frac{5}{2}(w - s)$$
$$\frac{ds}{dt} = \frac{2}{5}w - 90e^{-t}$$

- (a) Show that

$$2\frac{d^2w}{dt^2} - 5\frac{dw}{dt} + 2w = 450e^{-t}$$

(3)

- (b) Find a general solution for the number of white-clawed crayfish at time t years. (6)
- (c) Find a general solution for the number of signal crayfish at time t years. (2)

The model predicts that, at time T years, the population of white-clawed crayfish will have died out.

Given that $w = 65$ and $s = 85$ when $t = 0$

- (d) find the value of T , giving your answer to 3 decimal places. (6)
- (e) Suggest a limitation of the model. (1)



